

IPM

IN



SCHOOLS

ACTIVITY BOOK

(SECOND EDITION)

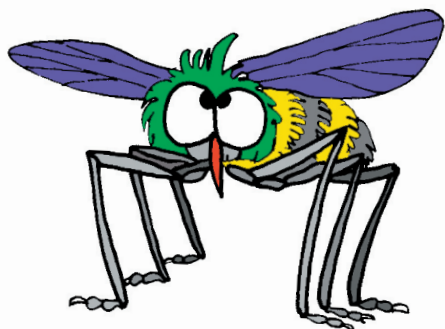

Look In **side**

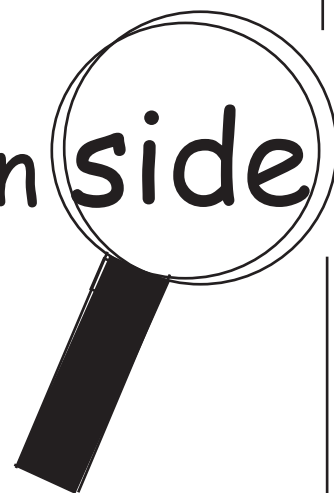
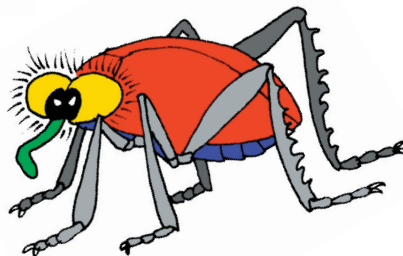

PURDUE
UNIVERSITY

TIMOTHY J. GIBB AND CHRISTIAN Y. OSETO

WELCOME!

LEARNING THE BEST WAY TO MANAGE PESTS AT HOME AND AT SCHOOL IS ONE WAY TO ENSURE A SAFE AND HEALTHY ENVIRONMENT IN WHICH CHILDREN CAN LIVE AND LEARN.

THE DEPARTMENT OF ENTOMOLOGY AT PURDUE UNIVERSITY IS PLEASED TO PROVIDE THESE FUN INTEGRATED PEST MANAGEMENT (IPM) EDUCATIONAL ACTIVITIES TO HELP TEACH THE MOST EFFECTIVE WAYS OF MANAGING PESTS.

COMPLETE THESE FUN ACTIVITIES WITH YOUR CHILD. IF STUMPED, YOU CAN CONSULT THE ANSWER KEY ON PAGE 19. WHEN YOU'RE DONE, PRESENT YOUR CHILD WITH THE CERTIFICATE ON THE BACK COVER.

BE AN IPM PEST DETECTIVE

WHAT IS IPM?

IPM USES THE BEST METHODS TO CONTROL PESTS. THESE METHODS INCLUDE KEEPING:

PESTS OUT,
THINGS CLEAN,
WATCH ON PESTS, AND
ACCURATE RECORDS.



PUBLICATION DEVELOPMENT FUNDING WAS PROVIDED BY A GRANT FROM THE U.S. ENVIRONMENTAL PROTECTION AGENCY.

PROJECT TEAM
TIM GIBB AND CHRIS OSETO, DEPARTMENT OF ENTOMOLOGY, PURDUE UNIVERSITY. ILLUSTRATIONS BY
CHRIS OSETO. SPECIAL THANKS TO JOANIE CORN AND AL FOURNIER.

A PEST DETECTIVE... KNOWS WHAT A PEST IS AND WHAT IT IS NOT.

CIRCLE THE PEST IN EACH PAIR.



ANTS IN THE KITCHEN

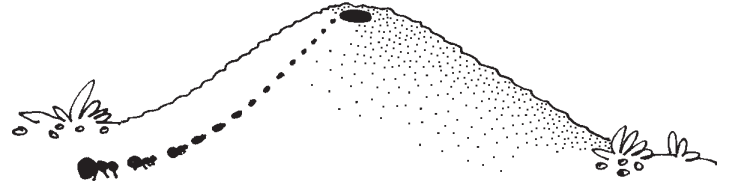

ANTS IN THE PARK

OR

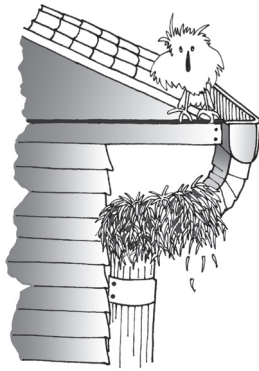

A BIRD NEST ON A
BUILDING



BIRD NEST IN A TREE

OR



DANDELIONS IN A VASE



DANDELIONS IN THE LAWN

OR

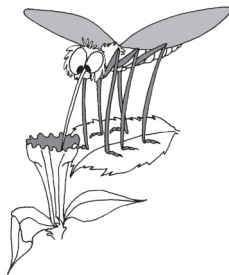

MOSQUITO FEEDING ON
A FLOWER



MOSQUITO FEEDING ON A
PERSON

OR



A PEST DETECTIVE... KNOWS WHAT AN INSECT IS.

INSECTS HAVE 3 PAIRS OF LEGS, AND 3 BODY PARTS, AND SOME HAVE WINGS.

CIRCLE THE INSECTS.

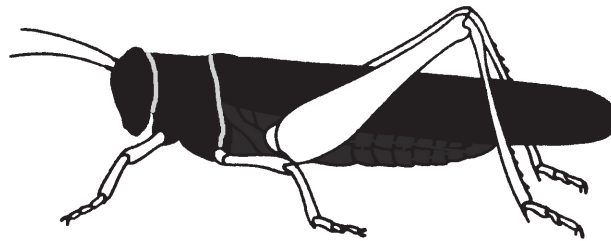
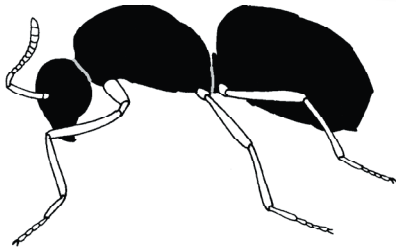
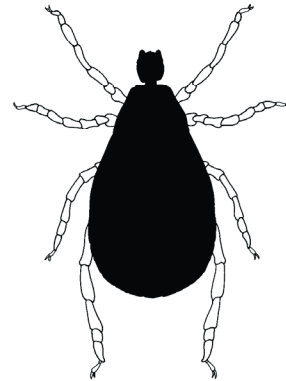
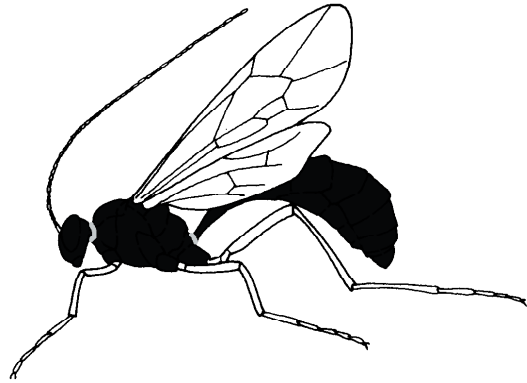
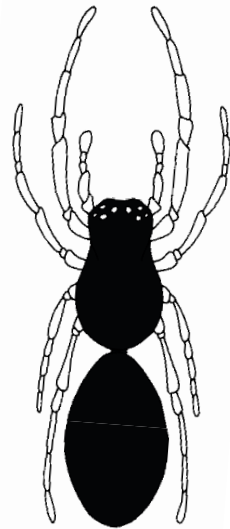
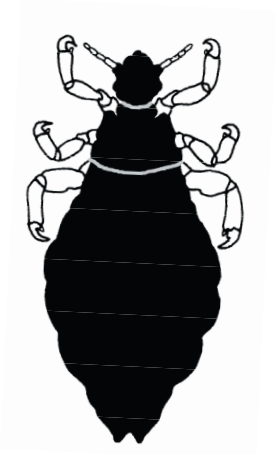

A PEST DETECTIVE... WORKS WITH CLUES.

THE THREE CARTOONS ON THE LEFT
STAND FOR INSECTS. DRAW A LINE FROM
THE CARTOON TO THE DRAWING OF A
REAL INSECT

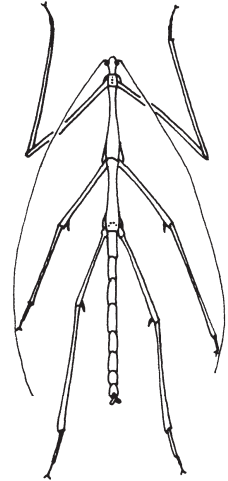
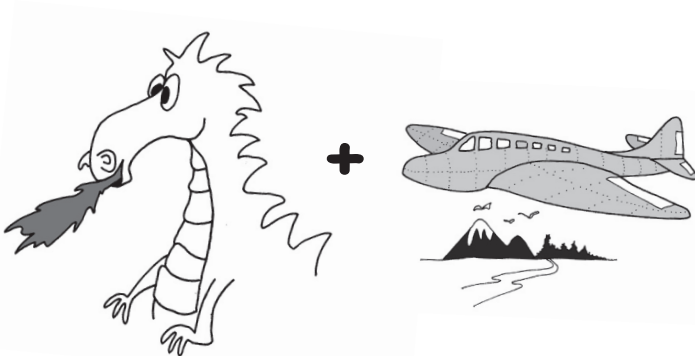
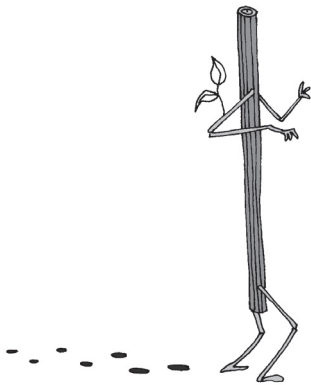
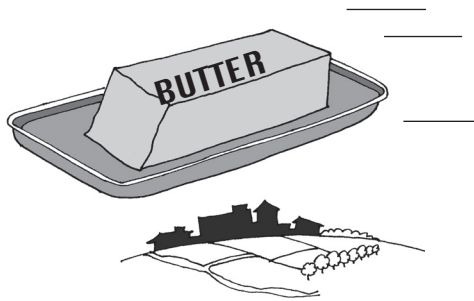

WALKINGSTICK

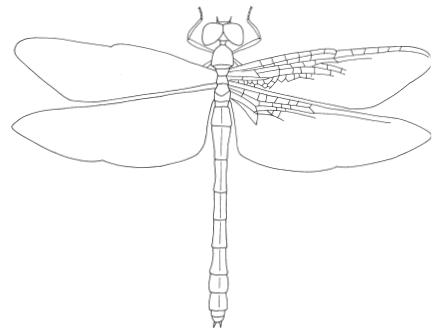

DRAGONFLY

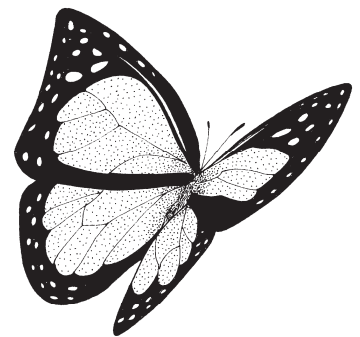

BUTTERFLY

A PEST DETECTIVE... KNOWS WHAT THINGS PESTS NEED.

PESTS NEED FOOD, WATER, AND SHELTER.

DRAW AN "X" THROUGH THE PICTURE THAT SHOWS WHAT PESTS LIKE.

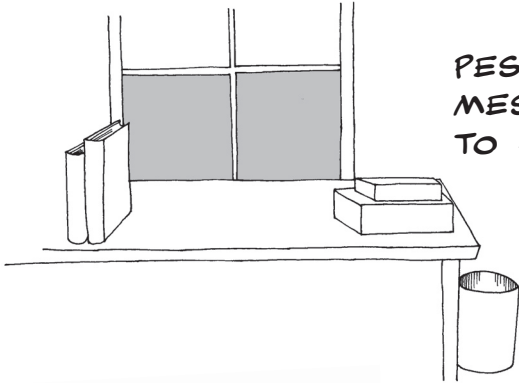

PESTS LIKE MESSY PLACES TO HIDE.

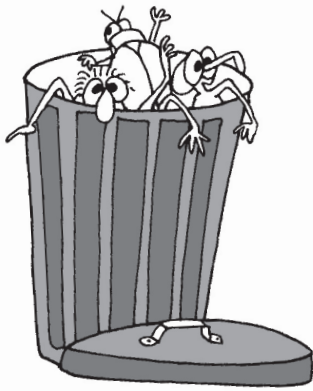

PESTS LIKE OPEN GARBAGE CANS.

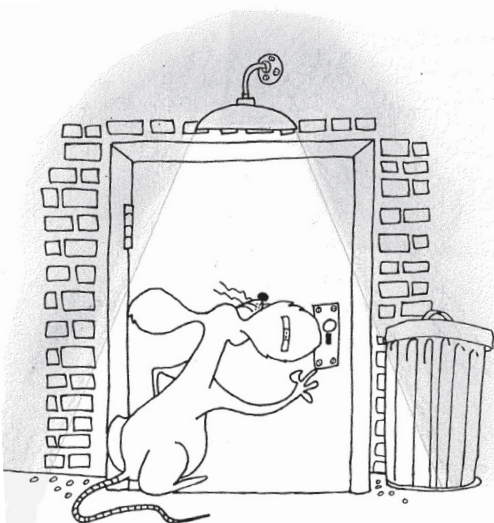
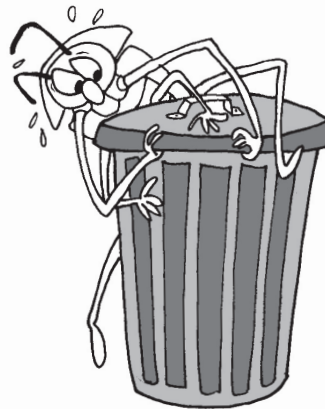

PESTS LIKE TO CRAWL THROUGH GAPS OR UNDER DOORS.

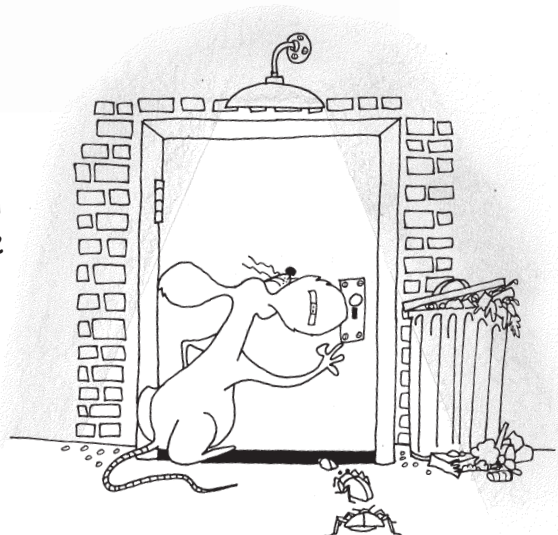

A PEST DETECTIVE... FINDS OUT HOW PESTS GET TO FOOD.

TRACE THE PATH TAKEN BY MICE TO
THE CHEESE. BE CAREFUL OF TRAPS!

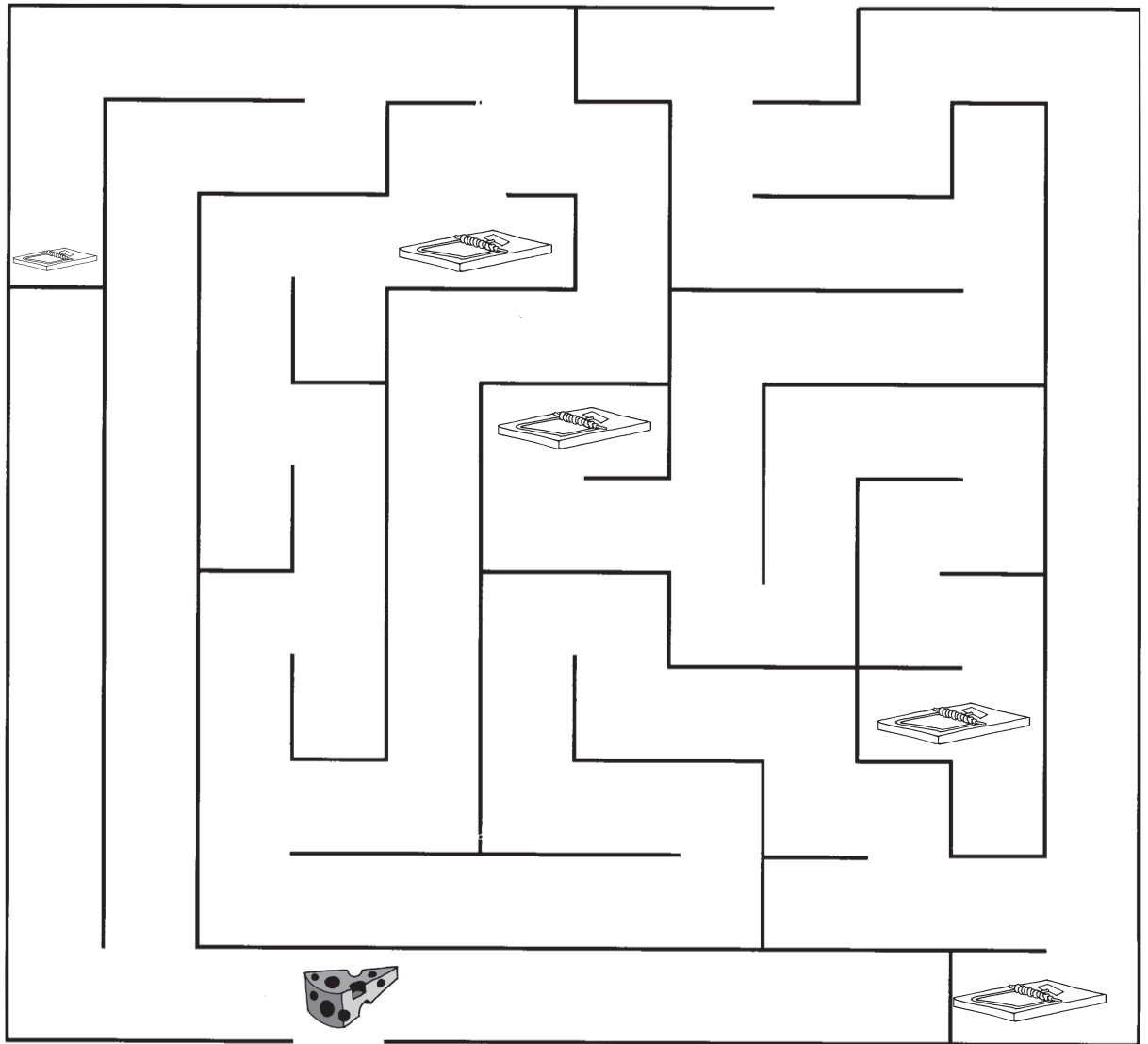

A PEST DETECTIVE... KNOWS IPM ARITHMETIC.

MATCH THE CORRECT WORDS ON THE RIGHT TO THE DRAWINGS BELOW AND SOLVE THE EQUATION.

PESTS
PESTICIDES
FOOD
TRAPS
WATER
ENTRANCE

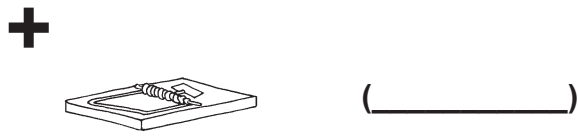
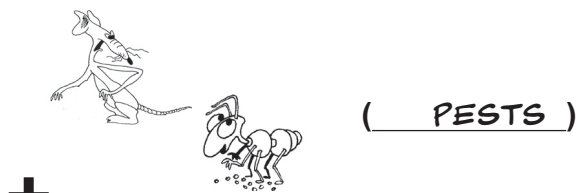

CONTROL FOREVER

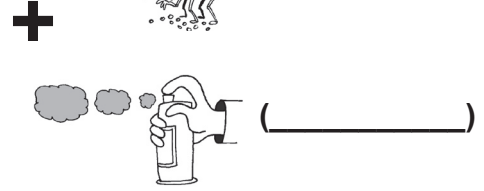
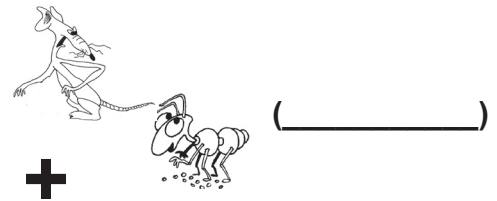

CONTROL FOR A DAY



I'M OUT OF HERE!



A PEST DETECTIVE... KNOWS HOW TO FIND INSECTS.

FIND AND COLOR 7 INSECTS HIDDEN IN THIS PICTURE.

DOESN'T
LOOK LIKE
ANY PESTS
HERE

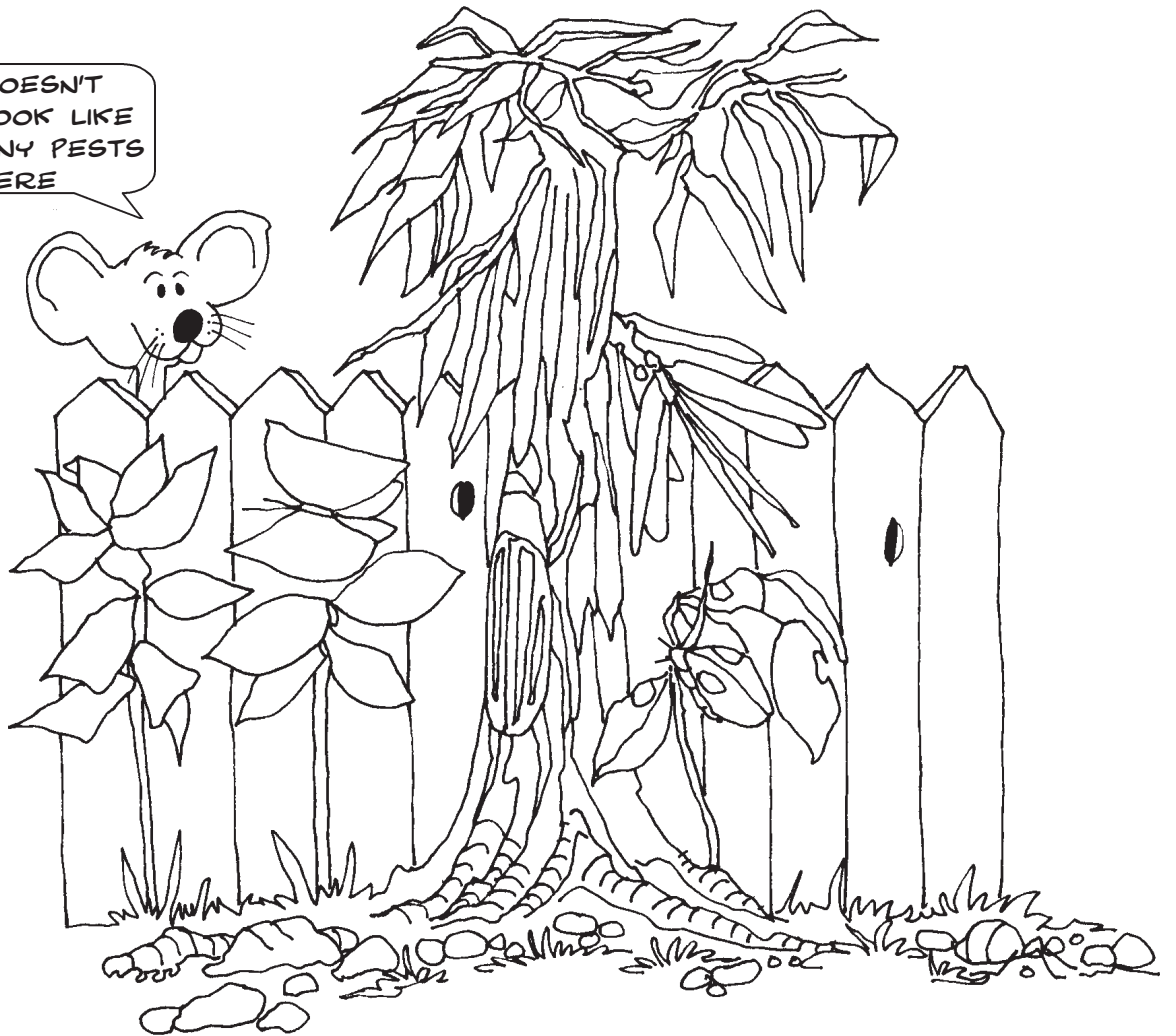

FIND THESE INSECTS IN THE PICTURE ABOVE.

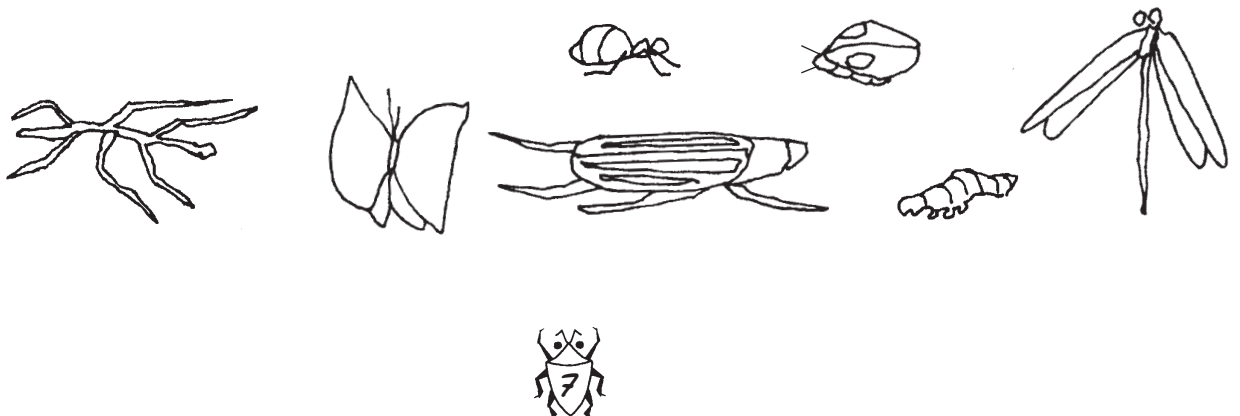

A PEST DETECTIVE... LOOKS FOR PESTS IN PLACES WHERE THEY HIDE.

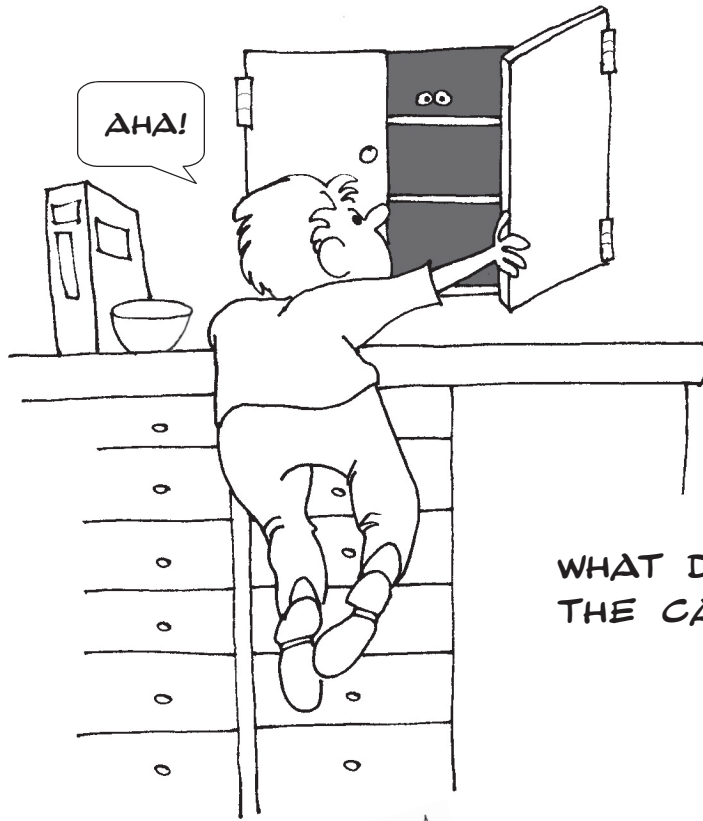

WHAT DO YOU THINK IS HIDING IN THE CABINET?



WHAT WOULD YOU USE TO CONTROL THIS "THING"?

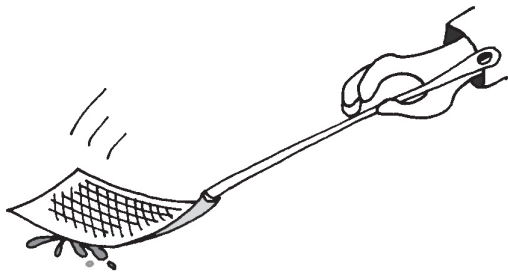

OR



A PEST DETECTIVE... MAKES REPAIRS TO KEEP PESTS OUT.

CIRCLE 10 THINGS THAT NEED TO BE FIXED SO
THAT PESTS CAN'T GET INTO THIS BUILDING.



FIND:

CRACKS IN FOUNDATION
SCREEN OFF WINDOW
DOOR WITH GAPS
BROKEN WINDOW
OPEN WINDOW
CRACKED CHIMNEY

WEEDY LAWN
TREE TOUCHING HOUSE
UNTRIMMED SHRUBS
RAIN GUTTER LOOSE
GARBAGE SCATTERED AROUND
MISSING SHINGLES



A PEST DETECTIVE... KNOWS HOW NOT TO BRING PESTS IN.

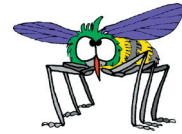

CIRCLE THE THINGS THAT CAN BRING
PESTS INTO SCHOOLS OR HOMES.

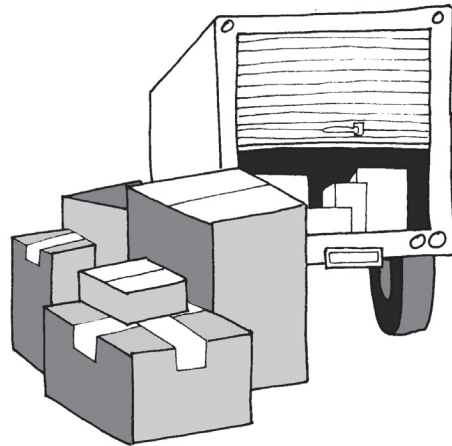
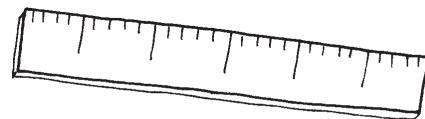
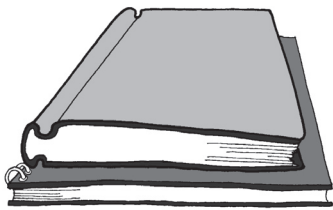

A PEST DETECTIVE... FOLLOWS DIRECTIONS TO DETERMINE WHAT THE PEST IS.

CONNECT THE DOTS, STARTING WITH DOT NUMBER ONE, AND FIND OUT WHAT THE COWBOY IS RIDING.

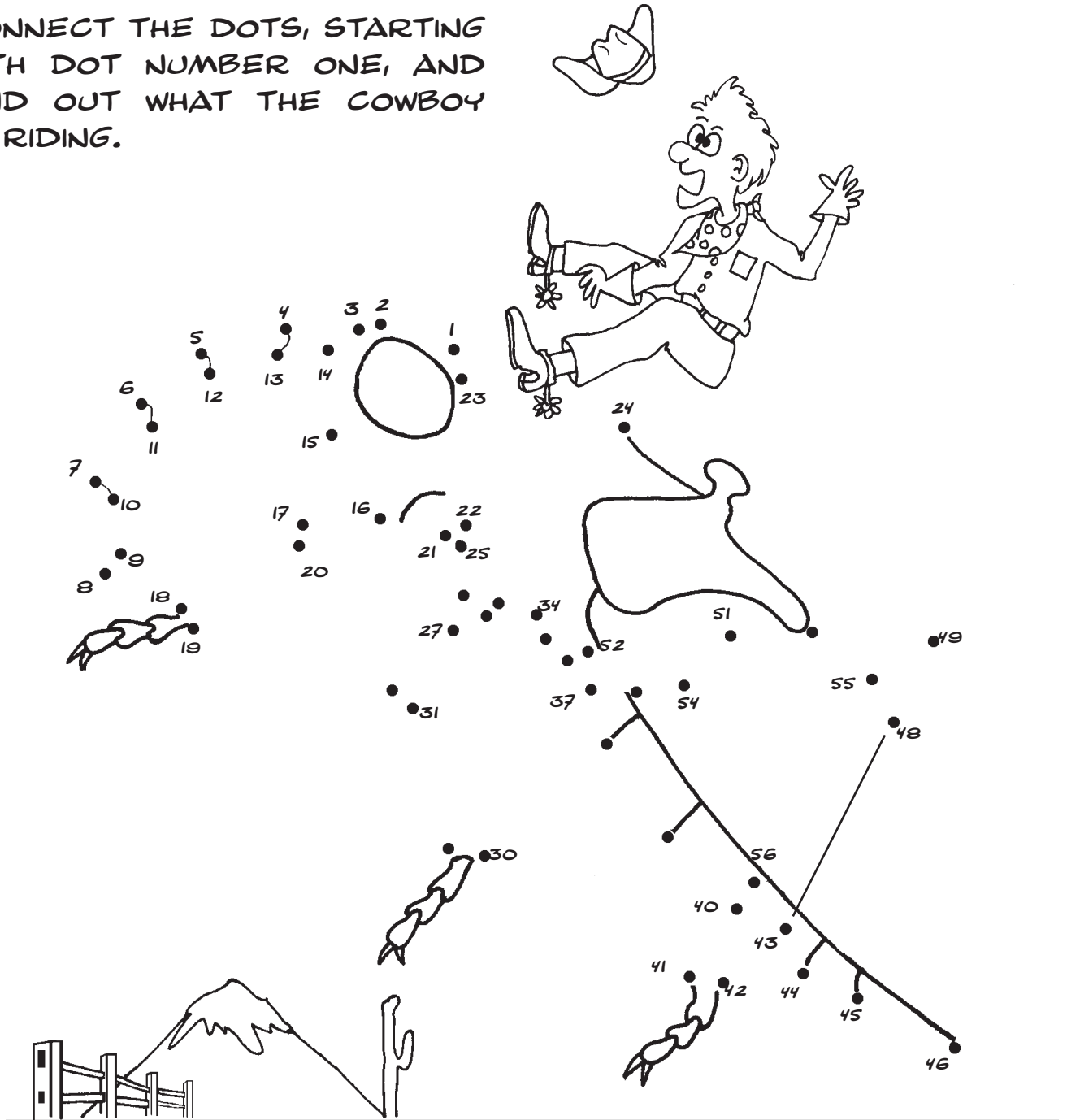

A PEST DETECTIVE... KNOWS WHAT PESTS LOOK LIKE.

COLOR THE BUTTERFLY
MATCHING THE COLORS TO THE
NUMBERS.

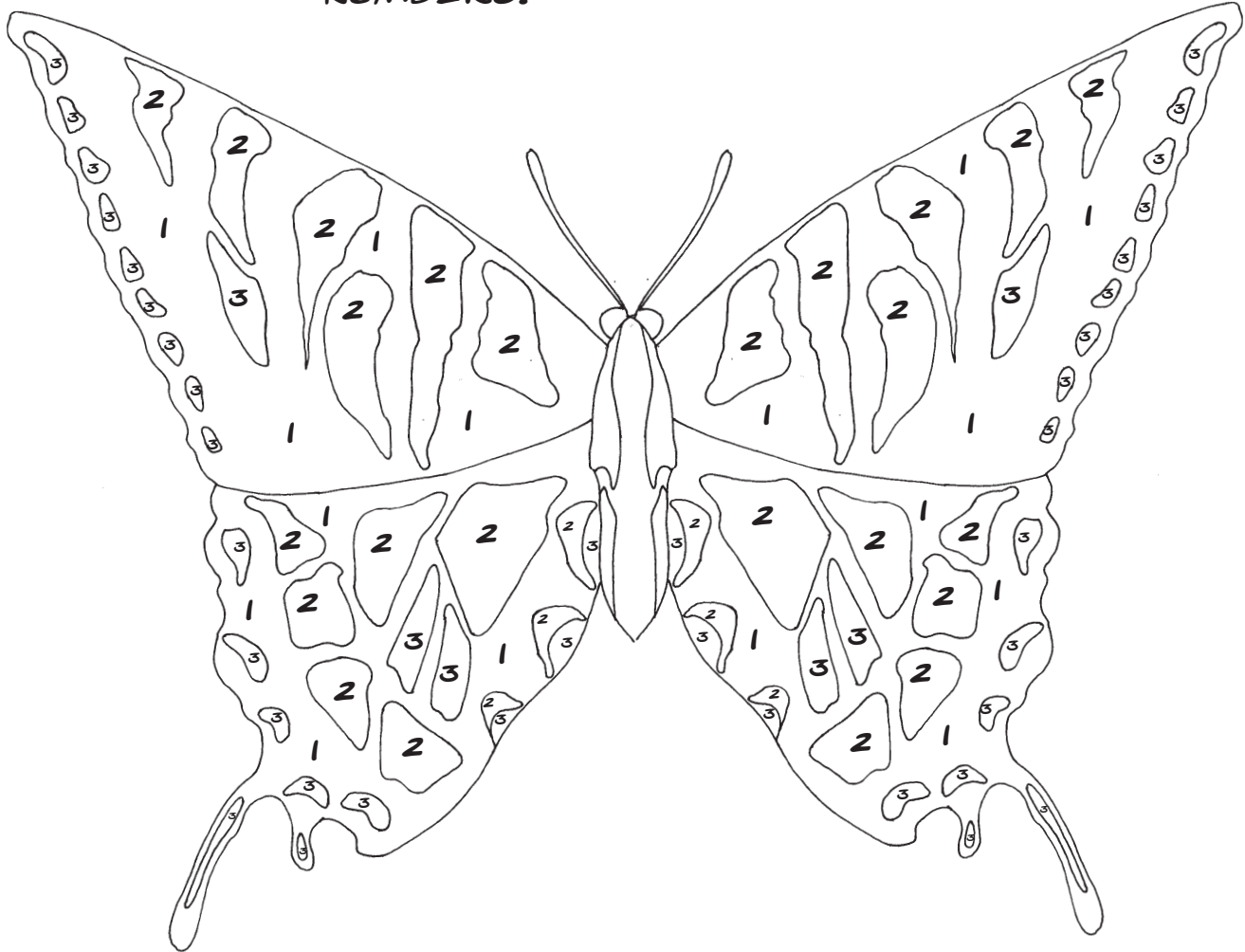

1 YELLOW



2 BLUE



3 RED

BUTTERFLIES ARE BEAUTIFUL INSECTS THAT ARE
NOT PESTS. REMEMBER, NOT ALL INSECTS ARE
PESTS AND NOT ALL PESTS ARE INSECTS.



A PEST DETECTIVE... USES THE RIGHT TOOLS TO DO THE JOB.

THESE KIDS WANT TO BE PEST MANAGEMENT PROFESSIONALS (A KIND OF PEST DETECTIVE). HELP THEM SELECT THE RIGHT TOOLS FOR THE JOB.



CIRCLE THE THINGS THAT A PEST MANAGEMENT PROFESSIONAL USES.



A PEST DETECTIVE... KNOWS MANY WAYS TO CONTROL PESTS.

BIOLOGICAL CONTROL IS THE USE OF ANIMALS TO CONTROL PESTS.

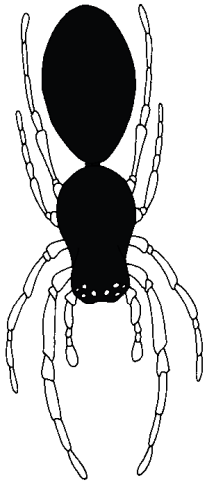
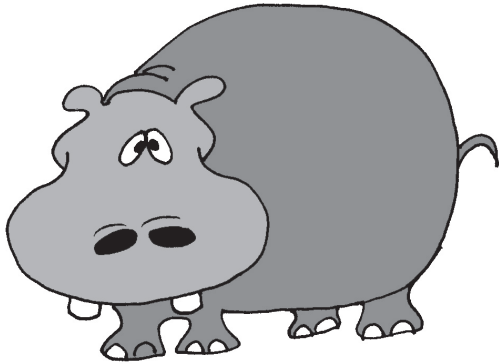

CIRCLE THE ANIMALS THAT EAT INSECTS.

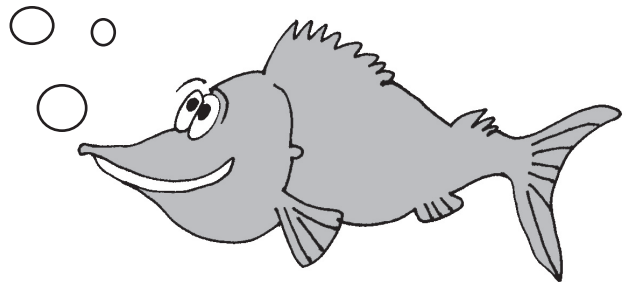
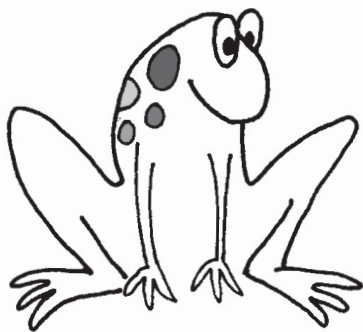

A PEST DETECTIVE...

KEEPS RECORDS.

I'VE GOT
A LOT OF
RECORDS



THOSE AREN'T
THE RIGHT
RECORDS

LOOK FOR PESTS AT
HOME OR SCHOOL
AND WRITE DOWN...



PESTS THAT YOU HAVE SEEN,

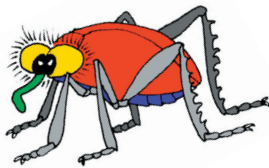

THE PLACES YOU HAVE LOOKED,



THE PROBLEMS YOU HAVE SPOTTED,

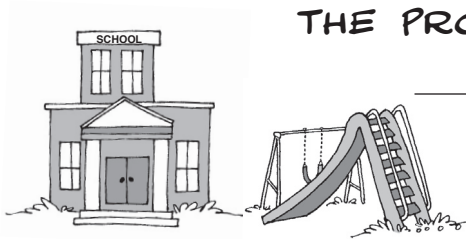

AND THE PEOPLE YOU HAVE TOLD
ABOUT THE PESTS.





A PEST
DETECTIVE... USES TOOLS TO HELP
FIND PEST PROBLEMS.

A STICKY TRAP CAN
BE USED TO FIND
MICE AND OTHER
PESTS.

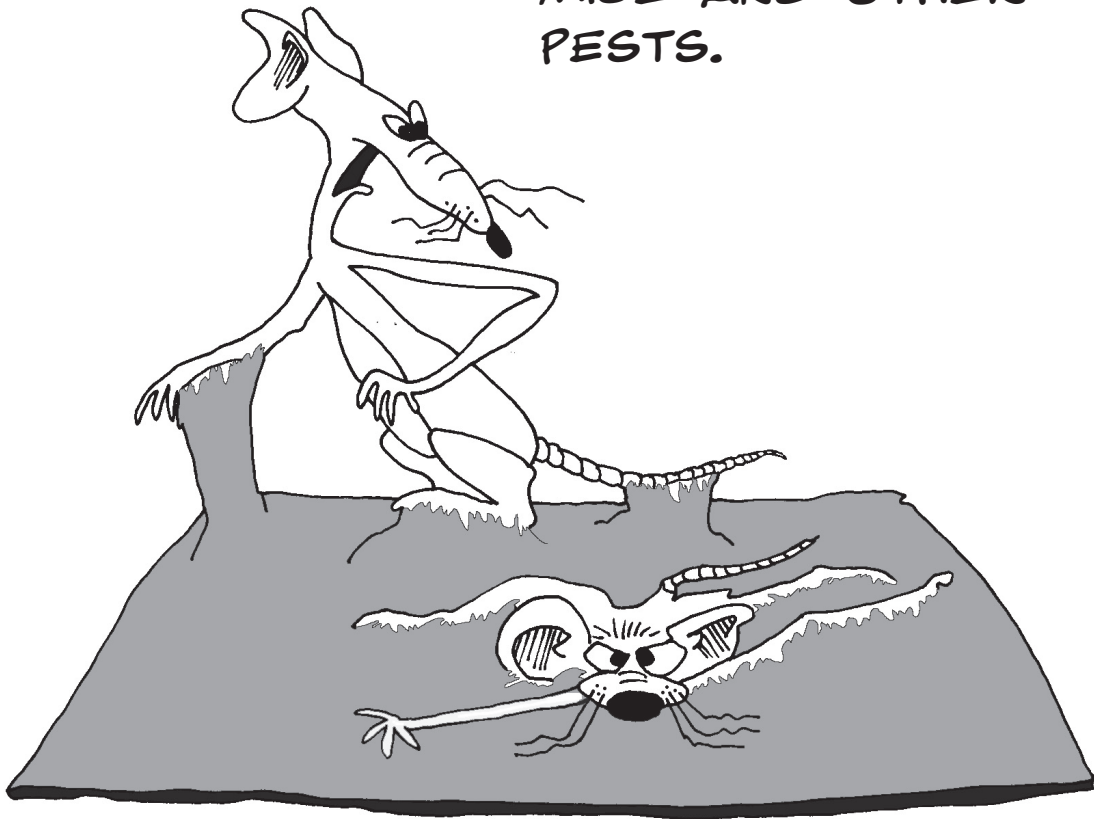

WHAT DO YOU THINK THE TWO
MICE ARE SAYING NOW?



A PEST DETECTIVE... HAS IMAGINATION.

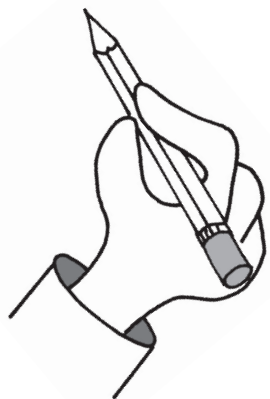
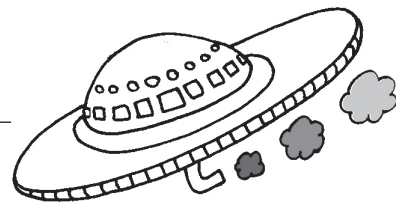

IMAGINE THAT YOU LIVE ON
MARS. DRAW WHAT YOU THINK
A PEST ON MARS WOULD LOOK
LIKE.



**A PEST
DETECTIVE... IS ALWAYS LOOKING FOR
WAYS TO IMPROVE.**

**THE WORLD NEEDS A
BETTER MOUSETRAP.**



**NO, DON'T
DO IT!**



**USE YOUR IMAGINATION TO DESIGN
AND DRAW A BETTER MOUSETRAP.**



WANT MORE INFORMATION ABOUT IPM IN HOMES OR SCHOOLS?

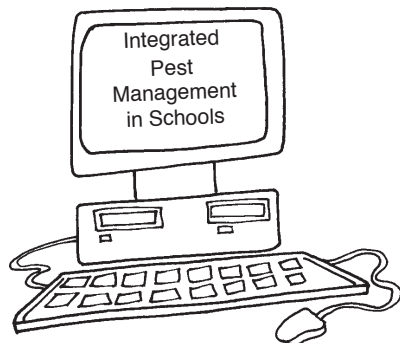

IPM IN SCHOOLS

WWW.ENTM.PURDUE.EDU/SCHOOLIPM

OR...



FILL IN WITH CONTACT INFORMATION FOR YOUR LOCAL PROFESSIONAL PEST MANAGER

ADDRESS: _____

PH: _____

FAX: _____

OR...



TIMOTHY J. GIBB
DEPARTMENT OF ENTOMOLOGY
PURDUE UNIVERSITY
SMITH HALL
901 W. STATE STREET
WEST LAFAYETTE, IN 47907-2089



CERTIFICATE OF GREAT WORK

KEEPING SCHOOLS SAFE AND FREE OF
PESTS IS IMPORTANT.



This is to certify that _____
has completed all activities and is now an official IPM Pest
Detective.

SIGNED _____
Parent, Guardian, or Teacher



IS YOUR SCHOOL USING
IPM? ASK YOUR PRINCIPAL
ABOUT

- IPM POLICY,
 - PEST SIGHTING LOG,
 - IPM SANITATION,
 - PEST MONITORING, AND
 - PEST EXCLUSION PRACTICES
- ...IN YOUR SCHOOL.



Purdue Extension

Knowledge to Go

1-888-EXT-INFO

New 1/2006

It is the policy of the Purdue University Cooperative Extension Service, David C. Petritz, Director, that all persons shall have equal access to the programs and facilities without regard to race, color, sex, religion, national origin, age, marital status, parental status, sexual orientation, or disability. Purdue University is an Affirmative Action employer.

1-888-EXT-INFO (398-4636)

<http://www.ces.purdue.edu/extmedia>